



HF-Regulator Intelligent Touch DALI for TL5/TL-D/PL-L lamps

HF-Ri TD 1 14/21/24/39 E+

This intelligent high-frequency electronic dimming ballast utilizes the DALI or Touch and Dim push-button protocol for fluorescent lamps. It meets A1BAT requirements, thereby pre-empting upcoming legislation. With a special command you can retrieve the system's mains power consumption, and with another you can find out which lamp wattage is connected. Combined with controls, additional energy savings can be achieved. The ballast is primarily designed for Indoor application. For outdoor application, the luminaire should be minimum Classland need to be sufficiently protected against water & dust. The installation should also be guard against any lightening surge or any other necessary electrical protection as deemed in such typical installation & application.

Product data

General Information		Number of Products on MCB (16A Type B) (Nom)	
Number of Lamps	1 piece/unit	30	
Operating and Electrical		Wiring	
Input Voltage	195-240 V	Connector Type Input Terminals	WAGO 251 universal connector [Suitable for both automatic wiring (ALF and ADS) and manual wiring]
Line Frequency	50 to 60 Hz		
Input Frequency	50 to 60 Hz		
Earth Leakage Current (Max)	0.5 mA		
Inrush Current Width	0.23 ms		
Inrush Current Peak (Max)	16.5 A		

HF-Regulator Intelligent Touch DALI for TL5/TL-D/PL-L lamps

Connector Type Output Terminals	WAGO 251 universal connector [Suitable for both automatic wiring (ALF and ADS) and manual wiring]
--	---

Temperature

Ambient temperature range	-25 °C to 50 °C
T-Case Lifetime (Max)	75 °C
T-Case Maximum (Max)	75 °C

Controls and Dimming

Control Interface	TD
--------------------------	----

Mechanical and Housing

Housing	L 360x30x21
----------------	-------------

Approval and Application

Ingress protection code	IP20 [Finger-protected]
Energy Efficiency Index	A1 BAT

Safety Standard	IEC 61347-2-3
Environmental Standard	ISO 14001
Approval Marks	CE marking ENEC certificate VDE-EMV certificate

Product Data

Full product code	871829169689600
Order product name	HF-Ri TD 1 14/21/24/39 E+
Order code	913700698366
Numerator - Quantity Per Pack	1
Numerator - Packs per outer box	12
Material number (12NC)	913700698366
Full product name	HF-Ri TD 1 14/21/24/39 E+
EAN/UPC - Case	8718291696902



Dimensional drawing

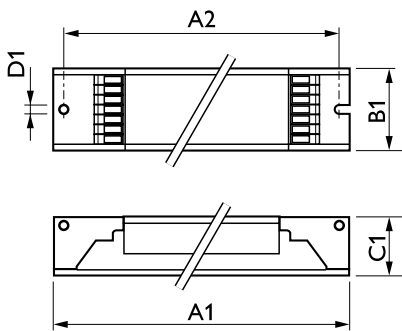

Product	D1	C1	A1	A2	B1
HF-Ri TD 1 14/21/24/39 E+	4.1 mm	21.0 mm	360.0 mm	350.0 mm	30.0 mm

