



MASTER LEDspot LV

MAS LEDspotLV D 8-50W 840 MR16 24D

Delivering intense accent beam, MASTER LEDspot LV is an ideal retrofit solution for spot lighting. MASTER LEDspot LV is designed to replace halogen or incandescent spots. It realizes natural colors, enables cozy and comfortable ambience for residential, hospitality and emphasizes the beauty of merchandise in retail. New smaller housing provides perfect fitting with majority of luminaires in a market with a MR16 GU 5.3 holder. It not only employs Philips' patented solution to guarantee the broadest possible compatibility with standard 12V halogen electronic transformers, it also delivers high beam intensity which is equivalent to halogen MR16 spots. The dimming function enables to create the desired atmosphere and it works with broad selection of dimmers. Its high SDCM ensure stricter color consistency, that is maintained over product life. MASTER LEDspot LV delivers huge energy savings and minimizes maintenance cost without any compromise on light quality and lifetime, enabling residential and business owners to achieve a return on their investment within short period time.

Product data

General Information		Operating and Electrical	
Cap-Base	GU5.3 [GU5.3]	Correlated Color Temperature (Nom)	4000 K
EU RoHS compliant	Yes	Luminous Efficacy (rated) (Nom)	83.00 lm/W
Nominal Lifetime (Nom)	40000 h	Color Consistency	<4
Switching Cycle	50000X	Color Rendering Index (Nom)	80
Technical Type	8-50W	LLMF At End Of Nominal Lifetime (Nom)	70 %
		Luminous Flux in 90° Cone (Rated)	670 lm
Light Technical			
Color Code	840 [CCT of 4000K]	Input Frequency	- Hz
Beam Angle (Nom)	24°	Power (Nom)	8 W
Luminous Flux (Nom)	670 lm	Lamp Current (Nom)	960 mA
Luminous Intensity (Nom)	3350 cd	Wattage Equivalent	50 W
Color Designation	Cool White (CW)	Starting Time (Nom)	0.5 s

MASTER LEDspot LV

Warm Up Time to 60% Light (Nom)	0.5 s
Power Factor (Nom)	0.7
Voltage (Nom)	12 V
Temperature	
T-Case Maximum (Nom)	100 °C
Controls and Dimming	
Dimmable	Yes
Mechanical and Housing	
Bulb Shape	MR16 [2inch/50mm]
Approval and Application	
Suitable For Accent Lighting	Yes

Energy Consumption kWh/1000 h	9 kWh
Product Data	
Full product code	871869681265500
Order product name	MAS LEDspotLV D 8-50W 840 MR16 24D
EAN/UPC - Product	8718696812655
Order code	929001881502
Numerator - Quantity Per Pack	1
Numerator - Packs per outer box	10
Material Nr. (12NC)	929001881502
Net Weight (Piece)	0.052 kg

Dimensional drawing

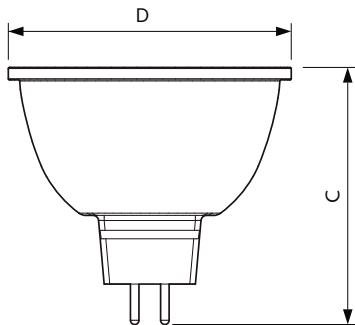

MR16 12V 8-50W 621lm 24D 4000K GU5.3 D

Product	D	C
MAS LEDspotLV D 8-50W 840 MR16 24D	50.5 mm	46.5 mm

Photometric data

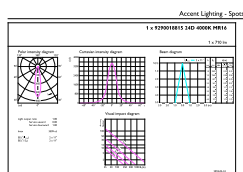

LEDspot MAS 8-50W GU5.3 MR16 840 24D DIM

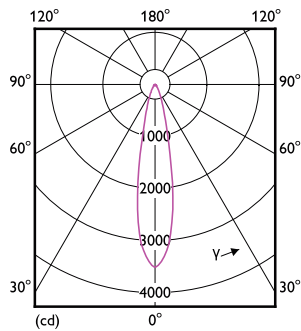

LEDspot MAS 8-50W GU5.3 MR16 840 24D DIM

MASTER LEDspot LV

Photometric data

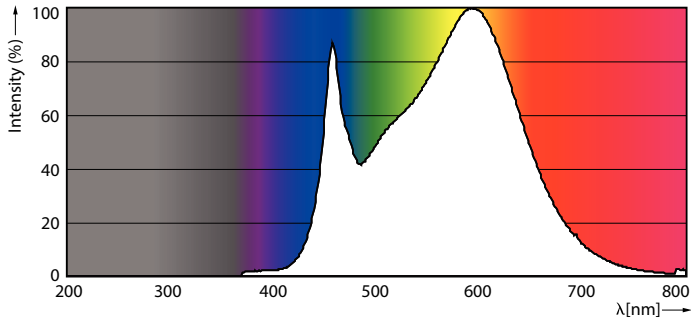

8-50W GU5-3 MR16

Lifetime

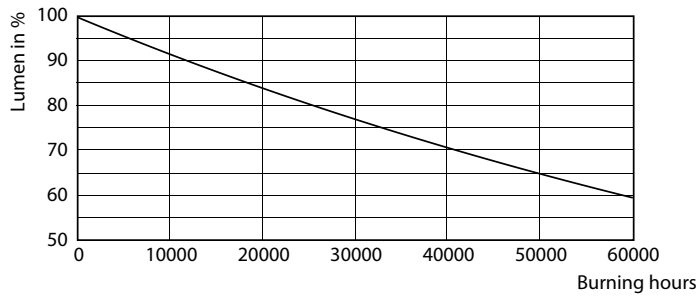

7-50W GU5-3 MR16

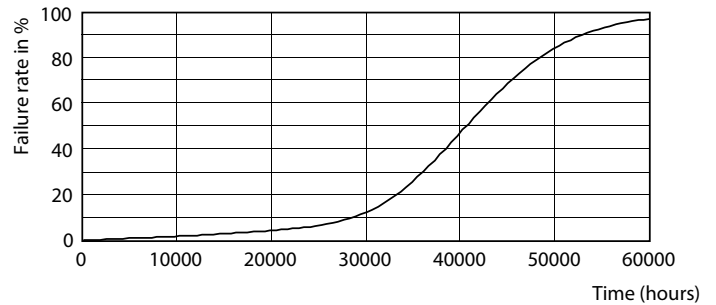

7-50W GU5-3 MR16

