



HF-Regulator II for TL-D lamps

HF-R 236 TL-D EII 220-240V 50/60Hz

High-frequency electronic dimming ballast, using the analog protocol (1-10 V) for TL-D lamps. The ballast is primarily designed for Indoor application. For outdoor application, the luminaire should be minimum Class II need to be sufficiently protected against water & dust. The installation should also be guard against any lightning surge or any other necessary electrical protection as deemed in such typical installation & application.

Product data

General Information	
Number of Lamps	2 piece/unit
Operating and Electrical	
Input Voltage	220 to 240 V
Line Frequency	50 to 60 Hz
Input Frequency	50 to 60 Hz
Earth Leakage Current (Max)	0.5 mA
Inrush Current Width	0.40 ms
Inrush Current Peak (Max)	45 A
Number of Products on MCB (16A Type B) (Nom)	12
Wiring	
Connector Type Input Terminals	WAGO 251 universal connector [Suitable for both automatic wiring (ALF and ADS) and manual wiring]
Connector Type Output Terminals	WAGO 251 universal connector [Suitable for both automatic wiring (ALF and ADS) and manual wiring]
Temperature	
Ambient temperature range	10 °C to 50 °C
Controls and Dimming	
Control Interface	1-10V
Mechanical and Housing	
Housing	L 360x30x21
Approval and Application	
Ingress protection code	IP20 [Finger-protected]
Energy Efficiency Index	A1 BAT
Safety Standard	IEC 61347-2-3
Environmental Standard	ISO 14001

HF-Regulator II for TL-D lamps

Approval Marks	CE marking ENEC certificate VDE-EMV certificate
Product Data	
Full product code	871150091015830
Order product name	HF-R 236 TL-D EII 220-240V 50/60Hz
Order code	913700609366
Numerator - Quantity Per Pack	1

Numerator - Packs per outer box	12
Material number (12NC)	913700609366
Full product name	HF-R 236 TL-D EII 220-240V 50/60Hz
EAN/UPC - Case	8711500910165



Dimensional drawing

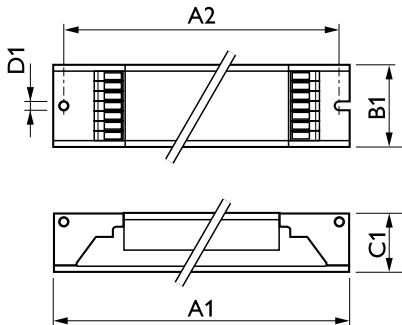

Product	D1	C1	A1	A2	B1
HF-R 236 TL-D EII 220-240V 50/60Hz	4.2 mm	22 mm	360 mm	350 mm	30 mm

