

SPECIFICATIONS

Power Supply	12V	Dimming Type	5-grade brightness touch dimmer
Lamp Illumination	> 1000LUX	Power wattage	9W
CRI	> 80Ra	Luminous Flux	> 400Lm
Lamp Color Temperature	Cold light:5500K±500K Warm light:3000K±280K Natural Light:4200K±400K		

Warranty Card

Applicable for

- * Since buying date, the user enjoys one year free repair services under normal use. After one year, will be charged according to each component part cost.
- * In case change component part, will be charged according to our company's component part cost list.
- * The following situations not free repair in warranty period
 - 1) Damage caused by natural earthquake, rat disaster, and unnormal use.
 - 2) Damage caused in transportation, fall, and unproper storage.
 - 3) Consumable component, such as spare parts, batteries, light bulbs, etc.
 - 4) Warranty information records is not complete, no purchase date, no buying shop seal, etc.
 - 5) Featured using environment, such as humidity, sulfur area, high salty and the ship, etc, easy corrosion area.
 - 6) Using not according to the instructions.
 - 7) Special offer.
- * When return to factory for repair, the user should make sure the LED lamp packed properly to avoid any damage during transportation.
- * Factory not responsible for the damages caused by the user themself unproper disassemble.

Attention

- * Do not self-disassemble the product, to avoid any electric shock.
- * Please use supplier's specified adapter and power socket, to maintain normal working.
- * Please do not over-adjusting the joint activity parts, to avoid any damage to the lamp.
- * Please do not put the lamps on the unstable desk to avoid the lamps dropping out.
- * Please do not put the lamp into high temperature or high-humidity environment.
- * Please do not look at the LED light source straightly, to avoid your eyes hurt.
- * In case below conditions occur, please pull out the power cord, stop using.
 - * If needed, please call for support staff:
 - * The power cord or power plug break
 - * The lamp holder damp or rain
 - * The shell and joint activities of the lamp holder breaks
 - * The lamp holder smokes or sparks
 - * The abnormal flickering or break of the LED light bulb

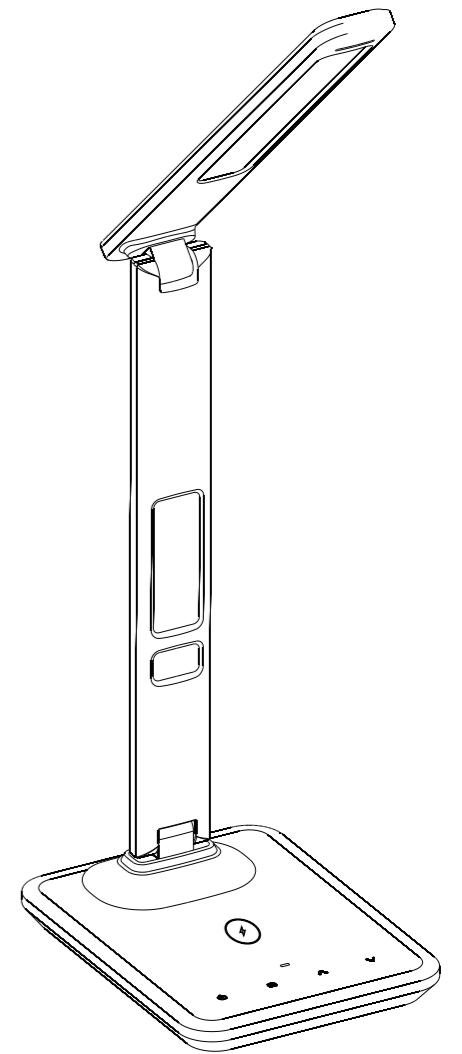

FUNCTION

- * Smart wireless charger, it can charge the smart watches and cell phones which is Qi wireless charging standard
- * High quality imitated leather design, can be used for long time. Advanced precision etching technology, to show more realistic imitated leather effect.
- * Touchable sliding for brightness, make it more convenient.
- * 5-grade brightness meet different lighting requirements.
- * 3 color temperature to choose. (Cold light, Warm light, Natural light)
- * Calendar.

USE MANUAL

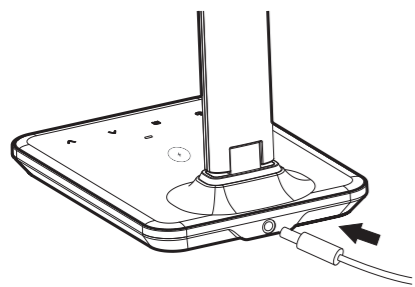

- * Insert the adaptor head into the socket behind the lamp

⚠️【Notice】 The power supply in the box is only for this lamp, forbid to use in other electrical appliances.

- * The range of activity for lamp:

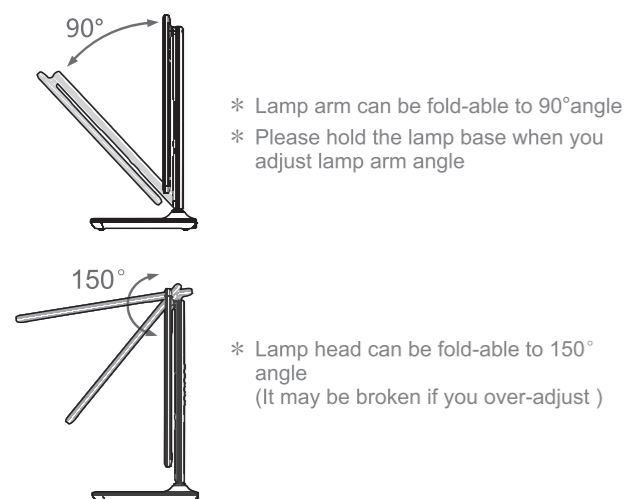

REPLACEMENT BATTERY

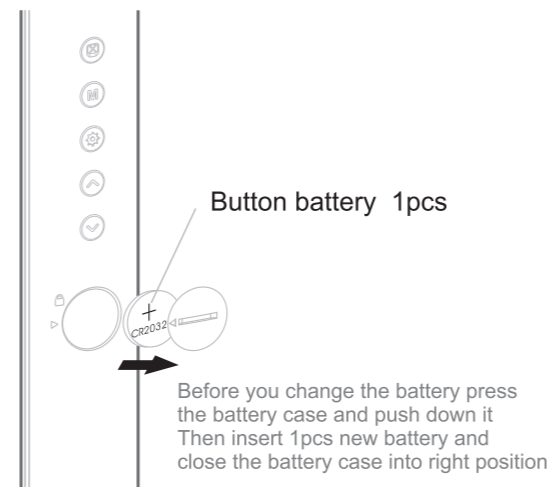

DISPLAY SCREEN BRIGHTNESS ADJUSTMENT

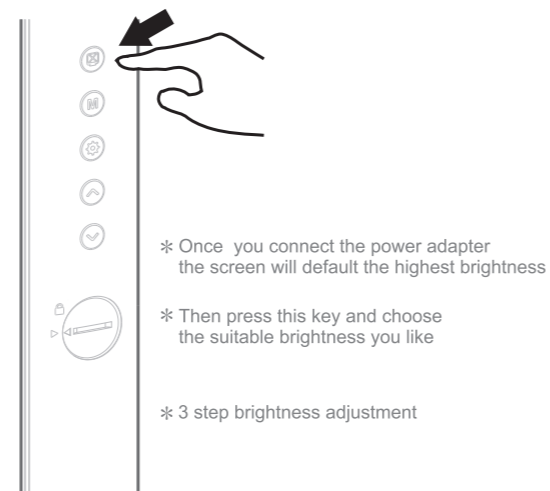

OPERATION GUIDE

- * Touch switch operation : (see the drawing)

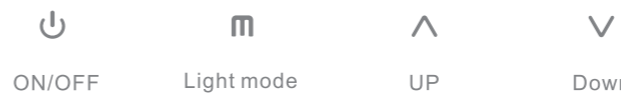

- * Calendar and alarm setting



- * Date and Time setting
 1. In normal mode, press "set" key to achieve setting functions, press against to move next, sequence:

Hour-Minute-Year-Month-Day.
 2. Press "up" and "down" to setting, week changes automatically when date change.
 3. In setting mode, press mode or stop operation in one minute to exit setting, and display time.
 4. In normal mode, press "down" key to switch between "12H" or "24H" display.

Snooze function setting

1. In normal mode, press "mode" key to active alarm setting.
2. In alarm mode, press "set" key to set the alarm time, sequence:

Hour-Minute-Snooze-Music-Exit.
3. Press "up" and "down" to setting
4. In alarm mode, press "up" and "down" to turn on/off alarm and snooze function, press again to achieve next function, sequence: alarm on- snooze on- alarm off- snooze off
5. When come to alarm time, will ring 1 minute, then snooze and ring again. Press any key to off alarm.

- * Temperature switch

In normal mode, press "down" key to switch between "F" and "C" display.

WIRELESS CHARGING INSTRUCTIONS

Put phone with Qi technical standard on the lamp base surface for charging, once light indicator turns to red and phone screen shows connecting that phone means charging successfully; If phone doesn't show connecting status, please check phone whether put to the wireless charging area correctly, or put phone on the base again, if still no working, kindly check the devices whether with Qi technical standard.

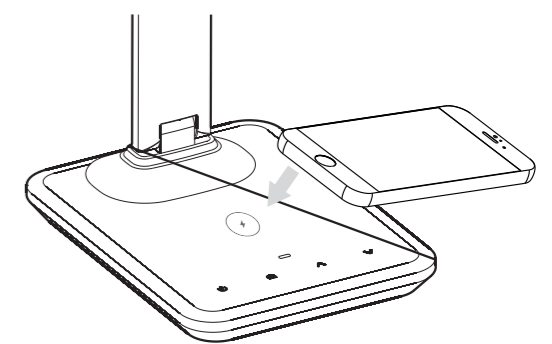

- * Lamp indicator light in red means that phone is charging status

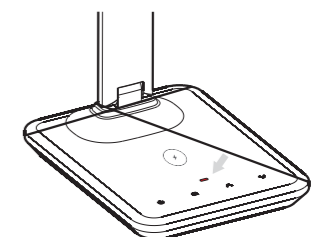

The red light flashing and start charging

- * The green light will light up when mobile phone is full charge. The cell phone battery symbol will also display a full charge state. (Only own function of wireless charging of mobile devices have a state of charge indicator function, there is no this indicator function if the mobile phone is equipped with a receiver when charging)

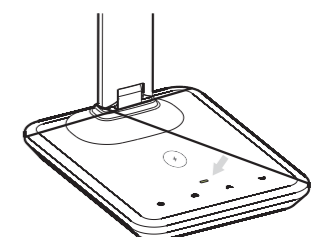

Green light, the charging is complete